

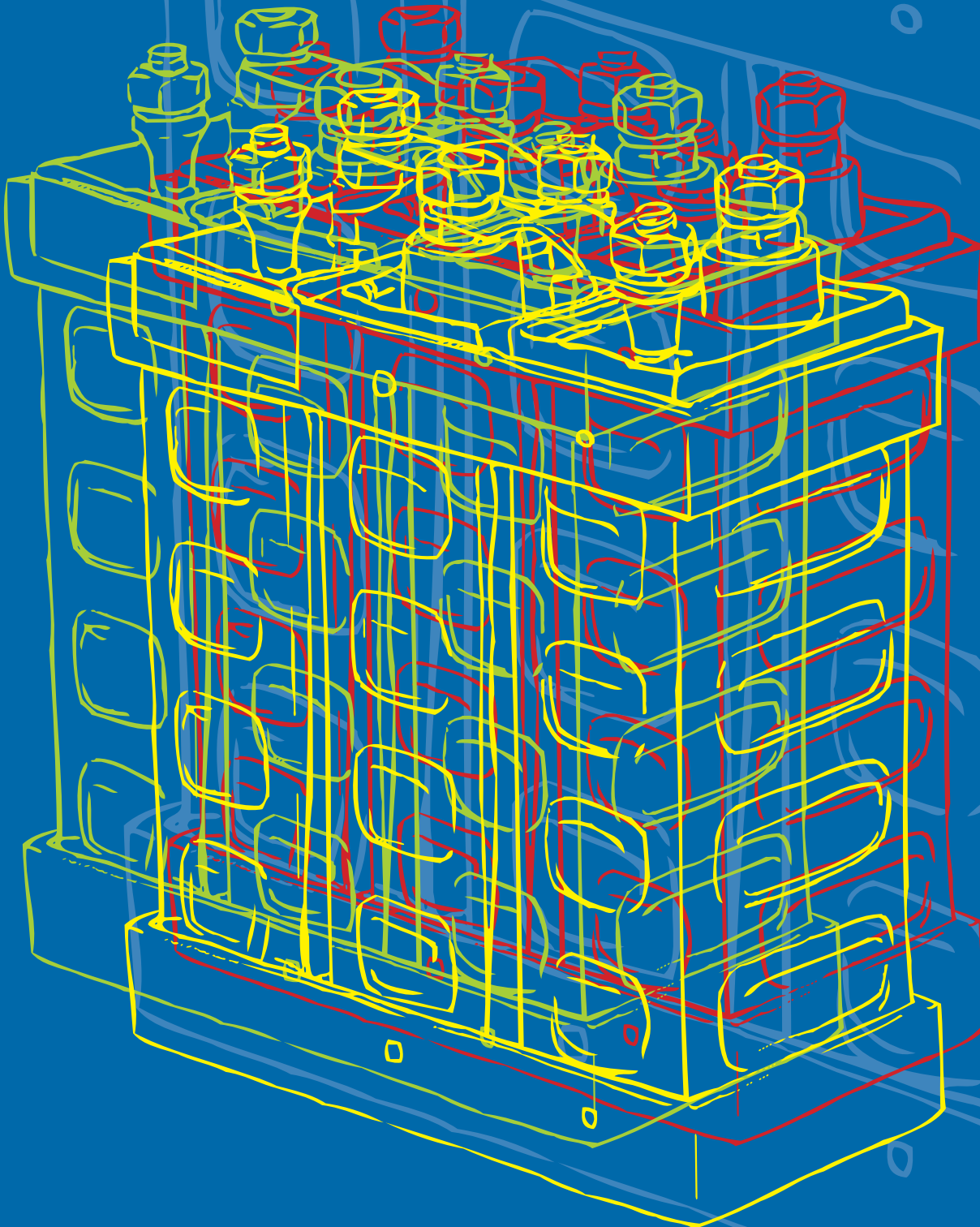

**VELIKIE LUKI
PLANT OF ALKALINE
ACCUMULATORS**



ISO 9001, CERTIFICATES, PERMITS, DIPLOMAS

The plant's goal is to entirely meet the requirements of our customers and continuously improve the products quality.

The plant's valid quality management system is based on the international ISO 9001 standard.

The compliance of the quality management system to the ISO 9001 requirements is proved with a certificate of TÜV NORD CERT GmbH and by regular compliance audits.

CJSC "Velikie Luki plant of alkaline accumulators" aims at confirming its products quality by voluntary and compulsory certification procedures, getting permits and approvals for delivery, taking part in the Russian contests between the best goods.

The plant has the Russian state standard certificates, permits and certificates from oversight bodies that represent sectorial consumers' interests.

Velikie Luki plant repeatedly has become a diploma winner of the Russian "100 Top quality goods".



ALKALINE ACCUMULATORS FOR INDUSTRIAL USE

Design features

The basic products of CJSC “Velikie Luki plant of alkaline accumulators” are electric accumulators with alkaline electrolyte and batteries completed out of them. The plant manufactures accumulators of two electrochemical systems:

- **nickel-iron**

A positive electrode is based on nickel-oxide, a negative electrode is based on ferriferous electrode material.

- **nickel-cadmium**

A positive electrode is based on nickel-oxide, a negative electrode is based on cadmium containing electrode materials.

Among products widely represented in our nomenclature there are accumulators of types FL, KL, KM, KH, and ТПНЖ (diesel locomotive starter nickel-iron) with the capacity from 55 to 550 Ah with pocket plate electrodes. Active material of such accumulators is contained inside of “boxes” out of thin metal perforated tape or pocket plate. This electrode design provides their high mechanical strength, high resistance to mechanical effects, and long life cycle. Accumulators of these types are produced in cases made out of impact- and freeze proof plastic, as well as in metal cases.

1 positive terminal

There is a polarity sign “+” by the positive terminal (painted red) on the accumulator cap.

2 plug

Provides electrolyte filling and free gas outlet when charging.

3 negative terminal

4 connecting element of contact banks into a block

Bolted connection for KH type, welded connection for KL, KM types. Provides connection between electrodes and a terminal.

5 contact bank

Contact bank, welded to electrode, provides electrode’s connection with the connecting element of contact banks. Punched contact blocks are used for assembly of bolted connection electrode blocks.

6 electrodes

7 separator

It divides positive and negative electrodes and provides free circulation of electrolyte between the electrodes.

8 case

It is made of plastic and metal. A rubber electrically insulating cover is put onto a metal accumulator case.

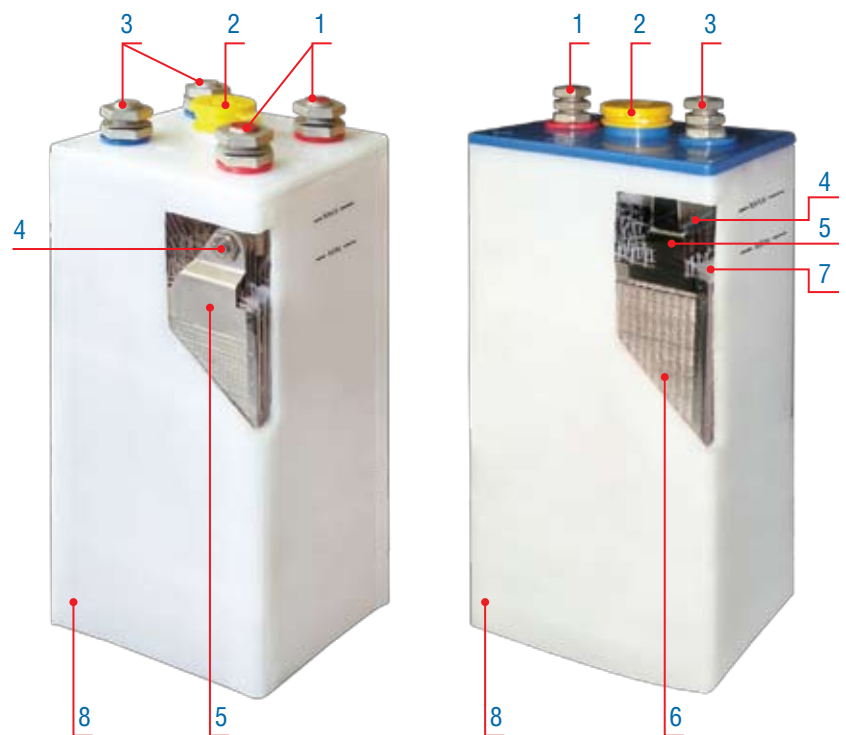

CJSC “Velikie Luki plant of alkaline accumulators” also produces a range of hermetically sealed portable nickel-cadmium accumulators of type KCSL with the capacity of 11 and 13 Ah. Pressurized and sintered positive electrodes and pressurized negative electrodes are used in this accumulator range. Fully-sealed accumulators of this range exclude electrolyte loss and do not require maintenance works related to electrolyte. Hermetically-sealed accumulators are produced in metal cases.

ALKALINE ACCUMULATORS FOR INDUSTRIAL USE

Accumulator marks approved by GOST P M3K 60623 recommendations

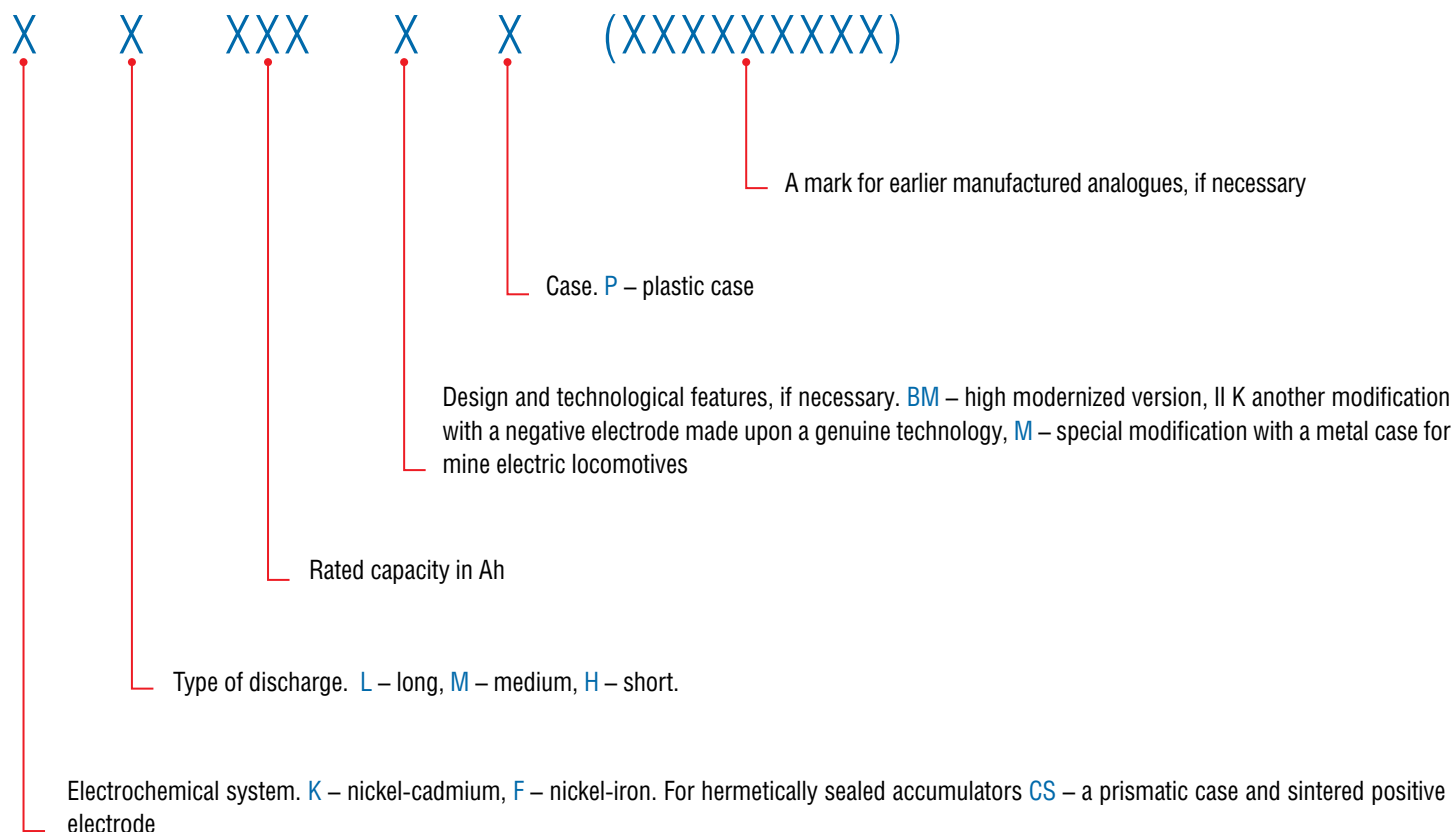

General advice on accumulator choice and operation

Meeting the requirements and recommendations given in the operational documentation (manuals, data sheets) provided together with our products secures a long life cycle of accumulators and batteries and their safety. It includes:

- proper storage conditions, starting, setup and maintenance of accumulators and batteries;
- securing the recommended charging rate and the positive balance of charge and discharge capacity;
- following safety rules and requirements.

DO NOT ATTEMPT TO OPEN AN ACCUMULATOR

If case you have any questions concerning the choice of accumulators and batteries, their maintenance and operation, please contact the plant's technicians.

ALKALINE ACCUMULATORS FOR INDUSTRIAL USE

When choosing an accumulator it is recommended to take into account a number of factors, which depend on the electrochemical system in use or physical and chemical nature as well as on the producer's constructive and technological solutions.

Various constructive solutions and techniques enable to produce accumulators adjusted to different current rates.

Characteristic curve of accumulators of various electrochemical systems and environment temperatures

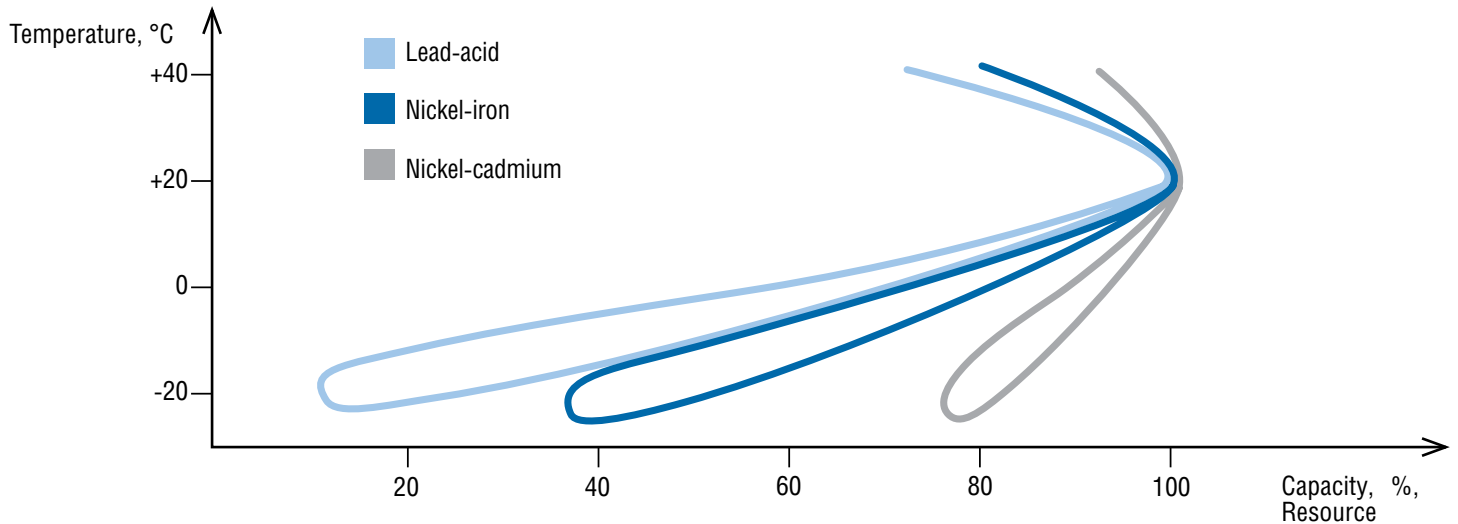

Recommended discharge rated duties for accumulators of different types according to GOST P M3K 60623(accumulators are grouped by discharge current value)

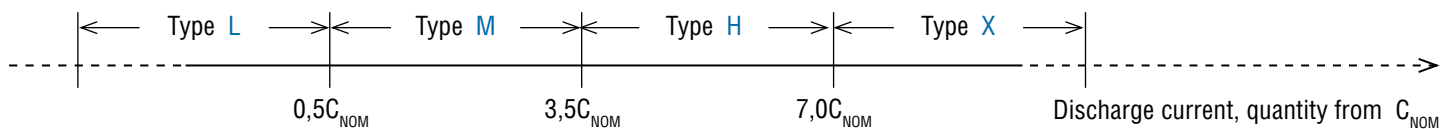

Application of Velikie Luki plant accumulators

APPLICATION: ■ BASIC ■ RECOMMENDED	ACCUMULATOR TYPE (RANGE)					
	FL ... P	FL ... M	KL ... P	KM ... P	KH ... P	KCSL
Floor-level transport	■					
Mine electric locomotives		■				
Railway cars	■		■	■		
Railway locomotives					■	
Railway electric trains and electric locomotives			■			
Sea and river transport			■	■	■	
Stationary emergency power system			■	■	■	
Portable and fixed equipment						■

Metal accumulator cases are good for conditions of high mechanical effects. Plastic case provides mechanical strength and durability, has the best electrically insulating properties, and secures visual electrolyte level control inside an accumulator.

Accumulators with alkaline electrolyte (nickel-iron and nickel-cadmium) are characterized by not only a wide operation temperature range, but tolerance to deep discharges and external faults.

NICKEL-IRON AND NICKEL-CADMIUM ACCUMULATORS FOR RAILWAY PASSENGER CARS

ACCUMULATOR TYPE		KM 300 P	KM 260 P	KL 375 P	FL 300 P	FL 350 P
Technical specifications		3482-005-49034134-2008	3482-002-49034134-2004	3482-013-49034134-2009	3482-011-00213351-94	3482-011-00213351-94
Rated capacity (C_{20}) Ah		300	260	375	300	350
Overall dimensions LxWxH, mm		128x167x400	128x167x400	128x167x400	130x167x400	130x167x400
Weight with electrolyte, no more than, kg		16	16	16	14,2	14,7
Weight without electrolyte, no more than, kg		11	10,8	11,2	10,5	11
Cell connection bolt per pole		M16	M16	M16	M16	M16
Rated discharge	Discharge current, A	60	52	75	60	70
	Medium discharge voltage, B	1,2	1,2	1,2	1,2	1,2
	Discharge time, h	5,0	5,0	5,0	5,0	5,0
	Final discharge voltage, B	1,0	1,0	1,0	1,0	1,0
Rated charge	Charging rate, A	60	52	75	60	70
	Charge time, h	8,0	8,0	8,0	8,0	8,0
	Final charge voltage (roughly), B	1,6	1,6	1,6	1,6	1,6

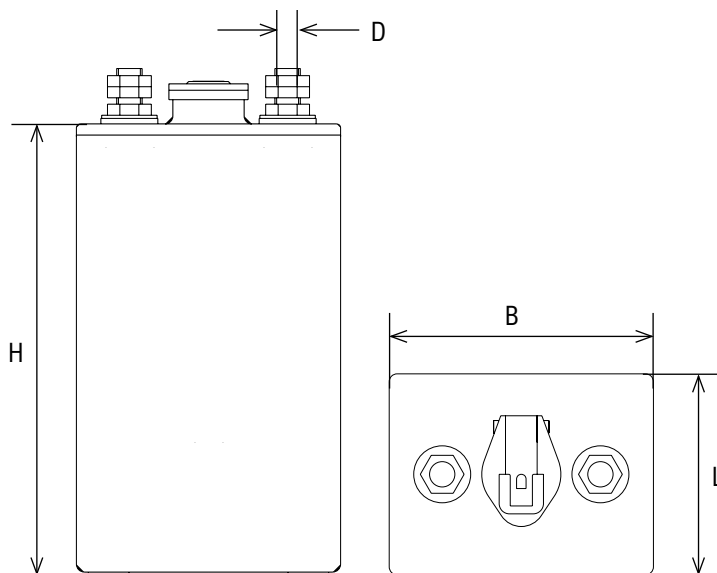

Another modification

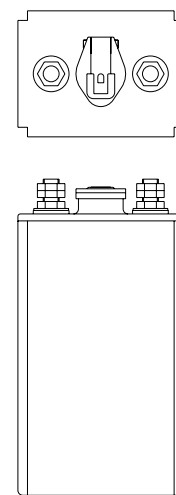

Accumulators as constituents of batteries are used for constant current power consumers in trunk railway passenger carriages equipped with air-conditioners and special-purpose railway carriages with the power supply system of 110 volts (batteries of 84 and 90 accumulators) and those with the power supply system of 50 volts (batteries of 40 accumulators).

WHEN ORDERING, PAY ATTENTION:

1. Carriage accumulators of type KM, which can be placed into battery bays with suspended breaker tracks, have special case modifications.
2. The accumulators' layouts within batteries may vary depending on the carriage type.

NICKEL-IRON AND NICKEL-CADMIUM ACCUMULATORS FOR RAILWAY LOCOMOTIVES AND ELECTRIC TRAINS

ACCUMULATOR TYPE	ТПНЖ-550-Y2	KH 220 P	2 KH 220 P	KH 150 P	5 KH 150 P	KL 125 P	KL 55 P
Technical specifications	3482-014-49034134-2009	3482-012-49034134-2009	3482-012-49034134-2009	3482-008-49034134-2009	3482-008-49034134-2009	3482-010-49034134-2008	3482-003-49034134-2008
Rated capacity (C_{20}) Ah	550	220	220	150	150	125	55
Overall dimensions LxWxH, mm	195x251x 484	174x170x 375	376x 176x 384	118x167x 367	638x198x 375	72x133x 354	60x114x235
Weight with electrolyte, no more than, kg	45,0	21,0	45,8	15,0	79,0	5,8	3,5
Weight without electrolyte, no more than, kg	32,5	16,2	36,6	11,0	65,0	4,3	1,95
Cell connection bolt per pole	M20	M20	M20	M20	M20	M10	M5
Rated discharge	110A till 1,0 B	44A till 1,0 B	44A till 1,0 B	30A till 1,0 B	30A till 1,0 B	25A till 1,0 B	11A till 1,0 B
Starter of 1 stage	2200A till 0,6 B	150A till 1,2 B	150A till 2,4 B	150A till 1,2 B	150A till 6,0 B	—	—
Starter of 2 stage	900A till 1,0 B	2200A till 0,65 B	2200A till 1,3 B	2000A till 0,65 B	2000A till 3,2 B	—	—
Rated charge	150A, 6 hours	44A, 8 hours	44A, 8 hours	30A, 8 hours	30A, 8 hours	25A, 8 hours	11A, 8 hours

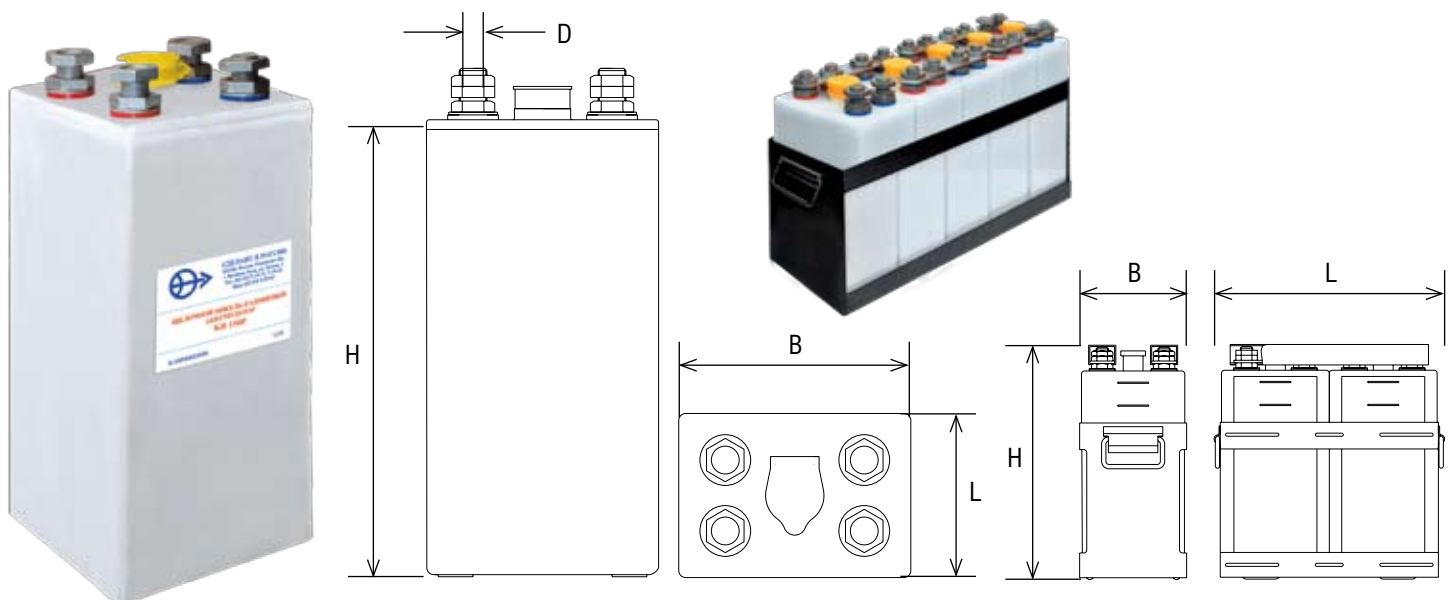

Accumulators of type KH and ТПНЖ-550 aim at starting-up the diesel engine of locomotive using a starter-generator or a traction generator, operating in a starter mode, and at constant current supply of drive circuit, lighting, auxiliary load when the diesel is out-of-run within accumulator batteries.

Batteries for electric trains and electric locomotives are completed with accumulators KL 55 P and KL 125 P.

NICKEL-IRON ACCUMULATORS FOR MINE ELECTRIC LOCOMOTIVES

ACCUMULATOR TYPE		FL 350 M	FL 500 M
Technical specifications		3482-019-00213351-95	3482-019-00213351-95
Rated capacity (C_5) Ah		350	500
Overall dimensions LxWxH, mm		165x167x538	165x167x538
Weight with electrolyte, no more than, kg		20,6	24,0
Weight without electrolyte, no more than, kg		16,8	20,2
Cell connection bolt per pole		M10	M10
Rated discharge	Discharge current, A	70	100
	Medium discharge voltage, B	1,2	1,2
	Discharge time, h	5,0	5,0
	Final discharge voltage, B	1,0	1,0
Rated charge	Charging rate, A	70	100
	Charge time, h	8,0	8,0
	Final charge voltage (roughly), B	1,6	1,6

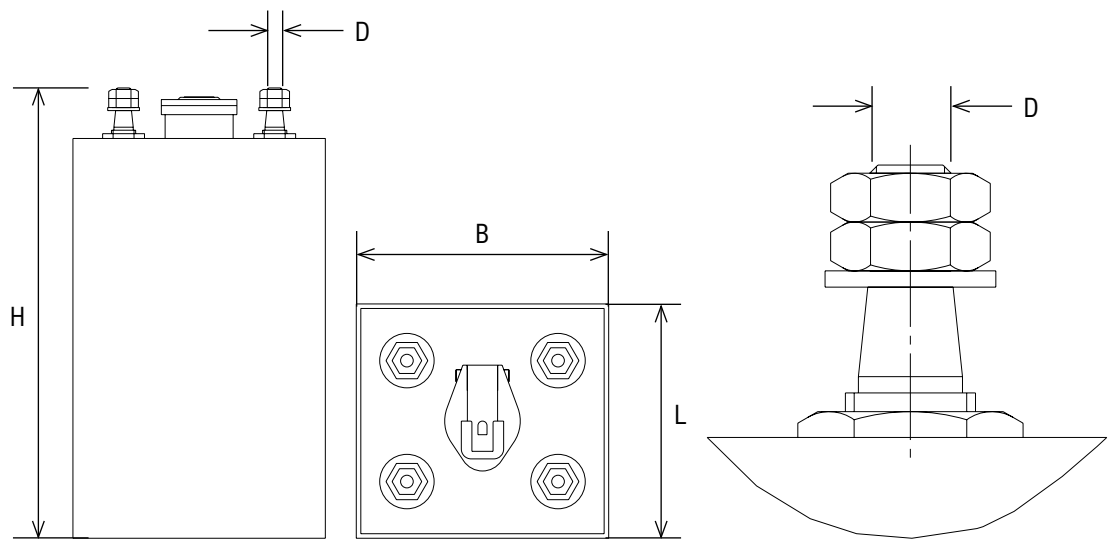

Accumulators of type FL 350 M and FL 500 M are manufactured in metal cases with a rubber electrically insulating cover. Terminals of accumulators have a cone-shaped contact part that secures a more reliable and safe connection with connection straps when assembling batteries.

Technical specifications 3482-019-00213351-95 provide schemes and a complete set for supply with connection straps for batteries assembly out of 96 and 112 cells.

Upon customer's wish sets of accumulators and connection straps for battery assembly of other combination upon essential schemes can be supplied.

NICKEL-CADMIUM ACCUMULATORS FOR CITY ELECTRIC TRANSPORT

ACCUMULATOR TYPE	KL 55 P	5 KL 55 P	KL 125 P	5 KL 125 P
Technical specifications	3482-003-49034134-2008	3482-003-49034134-2008	3482-010-49034134-2008	3482-010-49034134-2008
Rated capacity (C ₅) Ah	55	55	125	125
Overall dimensions LxWxH, mm	60x114x 235	125x 342x 221	72x 133x 354	147x 439,5x366,5
Weight with electrolyte, no more than, kg	3,5	16,5	5,8	31,6
Weight without electrolyte, no more than, kg	1,95	12,3	4,3	25,4
Cell connection bolt per pole	M5	M5	M10	M10
Rated discharge	Discharge current, A	11	11	25
	Medium discharge voltage, B	1,2	6,0	1,2
	Discharge time, h	5,0	5,0	5,0
	Final discharge voltage, B	1,0	5,0	1,0
Rated charge	Charging rate, A	11	11	25
	Charge time, h	8,0	8,0	8,0
	Final charge voltage (roughly), B	1,6	8,0	1,6

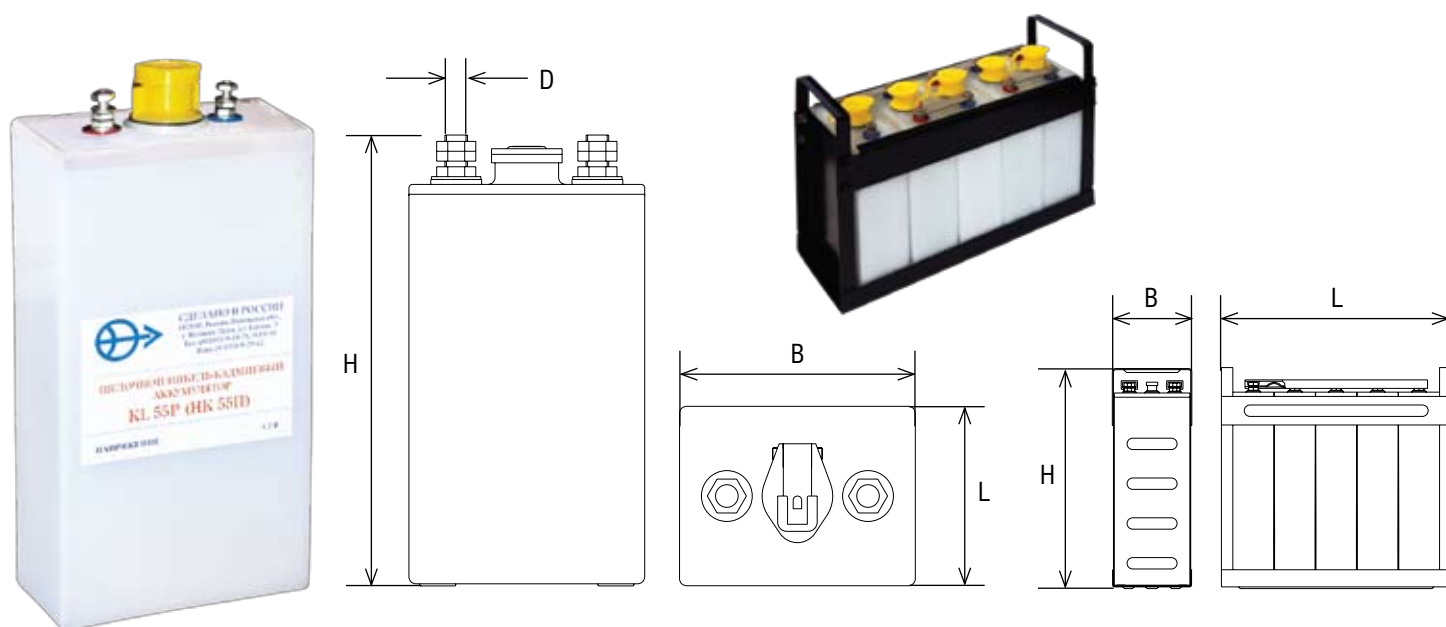

Accumulators of above mentioned type are manufactured in plastic cases.

They are used for a constant current supply in a long-term charge mode of power consumers in ground and underground electric transport (metro carriages, trams produced in Russia and Czech Republic). Accumulators can be supplied as single cells, in blocks of five cells set up in metal containers, or as battery sets with the number of accumulators and connection straps defined together with the customer.

NICKEL-IRON ACCUMULATORS FOR FLOOR-LEVEL ELECTRIC TRANSPORT

ACCUMULATOR TYPE	FL 250 P	FL 300 BMP	FL 400 P	FL 450	FL 350 II KP	FL 500 KP	
Technical specifications	3482-009-00213351-93	3482-009-00213351-93	3482-009-00213351-93	3482-009-00213351-93	3482-007-00213351-93	3482-007-00213351-93	
Rated capacity (C_{20}) Ah	250	300	400	450	350	500	
Overall dimensions LxWxH, mm	130x167x368	93x167x 485	130x167x485	130x167x485	95x167x 485	130x167x485	
Weight with electrolyte, no more than, kg	11,8	13,6	18,8	18,9	14,4	19,3	
Weight without electrolyte, no more than, kg	8,7	10,4	13,3	14,0	9,9	14,4	
Cell connection bolt per pole	M16	M16	M16	M16	M16	M16	
Rated discharge	Discharge current, A	50	60	80	90	70	100
	Medium discharge voltage, B	1,2	1,2	1,2	1,2	1,2	1,2
	Discharge time, h	5,0	5,0	5,0	5,0	5,0	5,0
	Final discharge voltage, B	1,0	1,0	1,0	1,0	1,0	1,0
Rated charge	Charging rate, A	50	60	80	90	70	100
	Charge time, h	8,0	8,0	8,0	8,0	8,0	8,0
	Final charge voltage (roughly), B	1,6	1,6	1,6	1,6	1,6	1,6

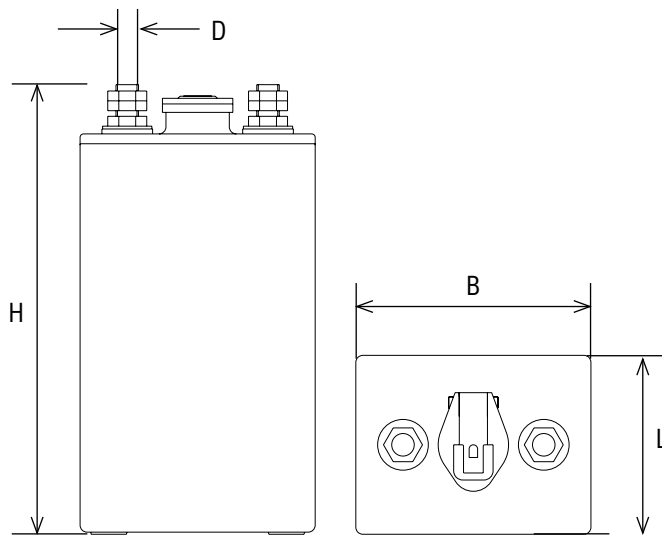

Accumulators of above mentioned type are manufactured in plastic cases.

Nickel-iron accumulators FL are used as battery constituents to supply energy for electromotors of floor-lever railless electric transport made in Russia – electric trucks, airplane ladders, electric lift trucks. Depending on the vehicle type the battery set may consist of 28, 30 (FL 250 P), 43, 36, 40 (FL 300 BMP, FL 350 II KP, FL 400 P, FL 450 P, FL 500 KP) accumulators.

NICKEL-CADMIUM ACCUMULATORS FOR SEA AND RIVER TRANSPORT, STATIONARY UNINTERRUPTED POWER SUPPLY

ACCUMULATOR TYPE		KL 55 P	KL 80 P	KL 125 P	KM 260 P	KM 300 P
Rated capacity (C_{20}), Ah		55	80	125	260	300
Overall dimensions LxWxH, mm		60x114x235	72x133x354	72x133x354	128x167x400	128x167x400
Weight with electrolyte, no more than, kg		3,5	5,1	5,8	16,0	16,0
Weight without electrolyte, no more than, kg		1,95	3,8	4,3	10,8	11
Cell connection bolt per pole		M5	M10	M10	M16	M16
Rated discharge	Discharge current, A	11	16	25	52	60
	Medium discharge voltage, B	1,2	1,2	1,2	1,2	1,2
	Discharge time, h	5,0	5,0	5,0	5,0	5,0
	Final discharge voltage, B	1,0	1,0	1,0	1,0	1,0
Rated charge	Charging rate, A	11	16	25	52	60
	Charge time, h	8,0	8,0	8,0	8,0	8,0
	Final charge voltage (roughly), B	1,6	1,6	1,6	1,6	1,6

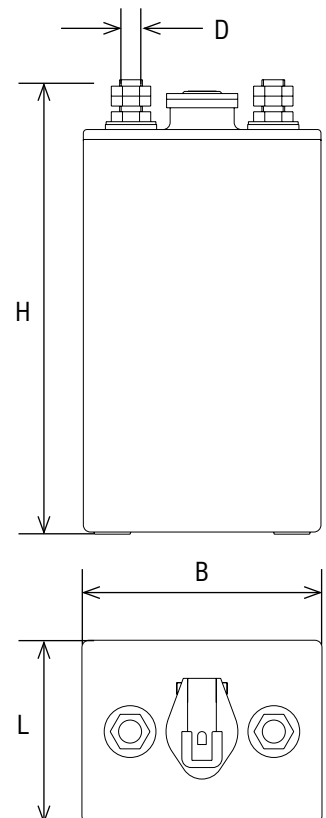

NICKEL-CADMIUM ACCUMULATORS FOR SEA AND RIVER TRANSPORT, STATIONARY UNINTERRUPTED POWER SUPPLY

ACCUMULATOR TYPE		KH 150 P	KH 220 P
Rated capacity (C_5) Ah		150	220
Overall dimensions LxWxH, mm		118x167x367	174x170x375
Weight with electrolyte, no more than, kg		15	21
Weight without electrolyte, no more than, kg		11	16,2
Cell connection bolt per pole		M20	M20
Rated discharge	Discharge current, A	30	44
	Medium discharge voltage, B	1,2	1,2
	Discharge time, h	5,0	5,0
	Final discharge voltage, B	1,0	1,0
Rated charge	Charging rate, A	30	44
	Charge time, h	8,0	8,0
	Final charge voltage (roughly), B	1,6	1,6
Starter discharge (two stages)	1 stage. Discharge current, A	150	150
	Till voltage, B	1,2	1,2
	2 stage. Discharge current, A	2000	2200
	Till voltage, B	0,65	0,65

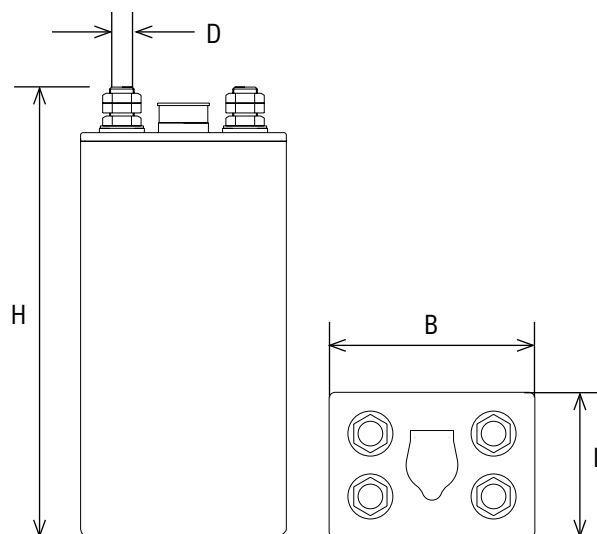

Design features and other data

Accumulators of all above mentioned ranges have cases made out of impact- and freeze proof plastic. Accumulators and compiled out of them batteries are designed for usage in the conditions of moderate and moderately cold climate without direct solar radiance and atmospheric precipitations.

Accumulators of KL range can be supplied in blocks of 5 accumulators set up in metal containers and connected with straps.

Accumulators of type KH 220 P can be supplied in blocks of 2, and type KH 150 P of 5 accumulators, set up into metal containers connected with straps.

Depending on application conditions (essential voltage of battery, placement of accumulators and batteries, etc.) the amount of accumulators within the battery set, the number and dimensions of connecting elements are to be coordinated when ordering.

Taking into account the expected discharge duty during usage for completing units of battery we recommend to choose:

- accumulators of range KL, when a rated discharge is required (current $0.2 C_5$, A);
- accumulators of KM range, when a rated discharge and short discharge are needed (up to 40 min) with current up to $1.0 C_5$, A;
- accumulators of KH range, when a rated discharge and spark discharge (up to 4 min) are needed with current up to $5.0 C_5$, A, and for a starter discharge of motor start-up.

When these nickel-cadmium batteries are used in optimum conditions with a typical regime for emergency power supply, their life cycle may last for 20 and more years.

PORTABLE NICKEL-CADMIUM ACCUMULATORS AND BATTERIES

ACCUMULATOR TYPE	KCSL 11	3 KCSL 11	KCSL 13	3KCSL 13
Technical specifications	3482-001-00213351-93	3482-001-00213351-93	3482-023-00213351-00	3482-023-00213351-00
Rated capacity (C_5) Ah	11	11	13	13
Overall dimensions LxWxH, mm	50x34,5x129	105,4x50,5x 131	50x34,5x129	105,x50,5x 131
Weight with electrolyte, no more than, kg	0,435	1,35	0,455	1,45
Cell connection bolt per pole	M6	M6	M6	M6
Rated discharge	Discharge current, A	2,2	2,2	2,6
	Medium discharge voltage, B	1,2	3,6	1,2
	Discharge time, h	5,0	5,0	5,0
	Final discharge voltage, B	1,0	3	1,0
Rated charge	Charging rate, A	1,1	1,1	1,3
	Charge time, h	12	12	12
	Final charge voltage (roughly), B	1,6	4,8	1,6

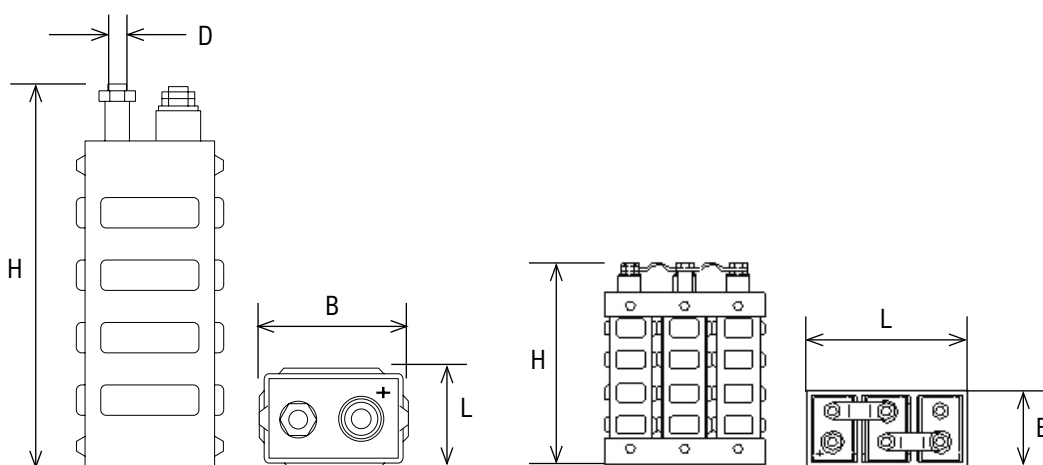

Batteries made out of 3 nickel-cadmium accumulators KCSL are used as current sources in mine cap lights and can be installed into various portable equipment.

Advantages of KCSL accumulators:

- no maintenance required
- normal operation under any placement
- overcharge resistance (current of 0.2 A, 28 days)

CAP LIGHTS AND ACCUMULATOR LIGHTS FOR INDUSTRIAL USAGE

ACCUMULATOR TYPE	MINE CAP LIGHT “IMPULSE”	CFBA 1 LIGHT	HAND LAMP “IMPULSE”	CFBA 2 LIGHT	CHARGING DEVICE 3Y-03
Technical specifications	3146-001-00213351-94	3146-002-00213351-99	3468-006-00213351-01	3146-004-00213351-00	—
Explosion protection type	РППИс	РВИbc	—	1ExL11BT4	—
Overall dimensions LxWxH, mm	150x76x174	150x65x174	215x76x221	150x65x171	152x72x70
Head lamp diameter, mm	76x80	76,5x85	76x80	76,5x85	—
Continuous lighting hours under normal conditions, no less than, h	10	10	10	10	—
Weight with electrolyte, no more than, kg	2,1	2,2	2,1	2,2	—



Mine cap light “Impulse”

It is used for local lighting workplaces at industrial enterprises and in underground workings of coal and shale mines characterized as gaseous-and-dusty ones. The light is specially explosion protected in accordance with GOST 12.2.020.

CFBA 1 light

It is used for lighting workplaces in underground workings, mines and pits, characterized as gaseous-and-dusty ones, as well as for operation in blind drifts and stope ores with outgoing air streams, in mines of category III and over. The light is explosion-proof according to GOST 12.2.020.

Hand light “Impulse”

Portable, with a handle, it is meant for local lighting in household, living and camping conditions, and for individual use in various industrial branches.

It is for in- and outdoor installation and for work in explosive zones and facilities where combustible gas, vapor or dust mixture (except explosive stuff dust) may form, which may explode because of a flame source. The light is explosion-proof according to GOST 12.2.020. Handle design upon customer’s wish.

Charging device 3Y-03

It is used for charging accumulator batteries inside the “Impulse” hand light and CFBA 2 light.

JOINTING PRODUCTS AND SHIPPING

JOINTING PRODUCTS AND SHIPPING

Jointing products and related services

CJSC “Velikie Luki plant of alkaline accumulators” offers electrolytes based on alkali:

- sodium and potassium electrolyte with/without lithium for nickel-iron accumulators;
- potassium electrolyte with lithium for nickel-cadmium accumulators.

These electrolytes comply with the requirements and recommendations of МЭК 993, GOST P 50711 and accumulator operational manual of Velikie Luki plant. If necessary, an alkaline electrolyte of special composition agreed with a customer can be supplied. It is possible to supply strong caustic or high density alkaline electrolyte subject to diluting necessary for electrolyte adjusting during accumulator operation.

Alkaline electrolytes and solutions are made:

- in original containers, plastic ones with up to 30 liters capacity, or steel drums;
- in customer’s steel containers that can be closed tight and meet the alkali transfer and storage requirements.

At customer’s wish the plant may assist in making a choice and supplying of necessary items for accumulator maintenance and electrolyte preparation:

- equipment;
- devices and tools;
- protective means for maintenance staff.

The plant accepts spent nickel-cadmium and nickel-iron accumulators for disposal and recycling.

Products shipping

Shipping is done in transport packs. Packing materials, produced according to the plant’s norms and specifications, prevent products from damage if the handling instructions are followed. Transport packs enable to store the product according to the timeline and conditions set in the operation manual and data sheets, provided alongside when shipping.

The plant ships its products by railway and road transport. At the customer’s will, products can be loaded out for pick up with a vehicle with a closed body, equipped with canvas for atmospheric precipitations protection.

Our sales department may assist with further concrete information concerning product shipping and transfer, including shipment volumes, procedure, crossing the Russian border.

Telephone: 8 (81153) 91875

Tel./Fax: 8 (81153) 91771
8 (81153) 92873

E-mail: mail@akbluki.ru
alk77@yandex.ru

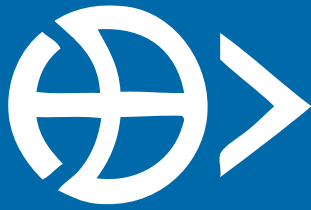

VELIKIE LUKI PLANT OF ALKALINE ACCUMULATORS

HOW TO REACH US

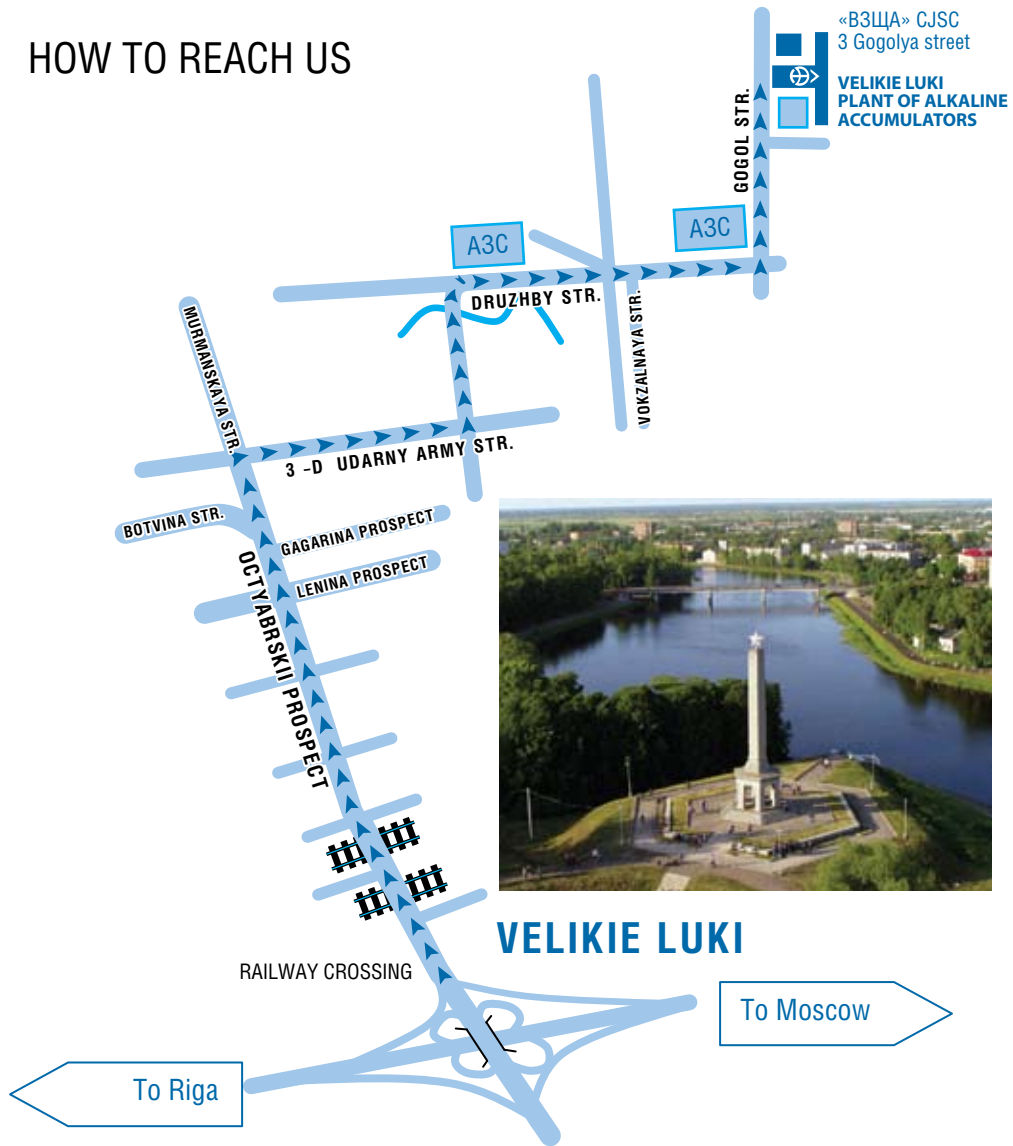

3 Gogolya street
182100 Velikie Luki
Pskov region
RUSSIA

Tel.: 881153 91875

Tel./Fax: 881153 91771, 92873

E-mail: mail@akbluki.ru

www.akbluki.ru